

Connection hoses and cables	
Water hose:	✗
Waste water hose:	✗
Electric cable:	✓

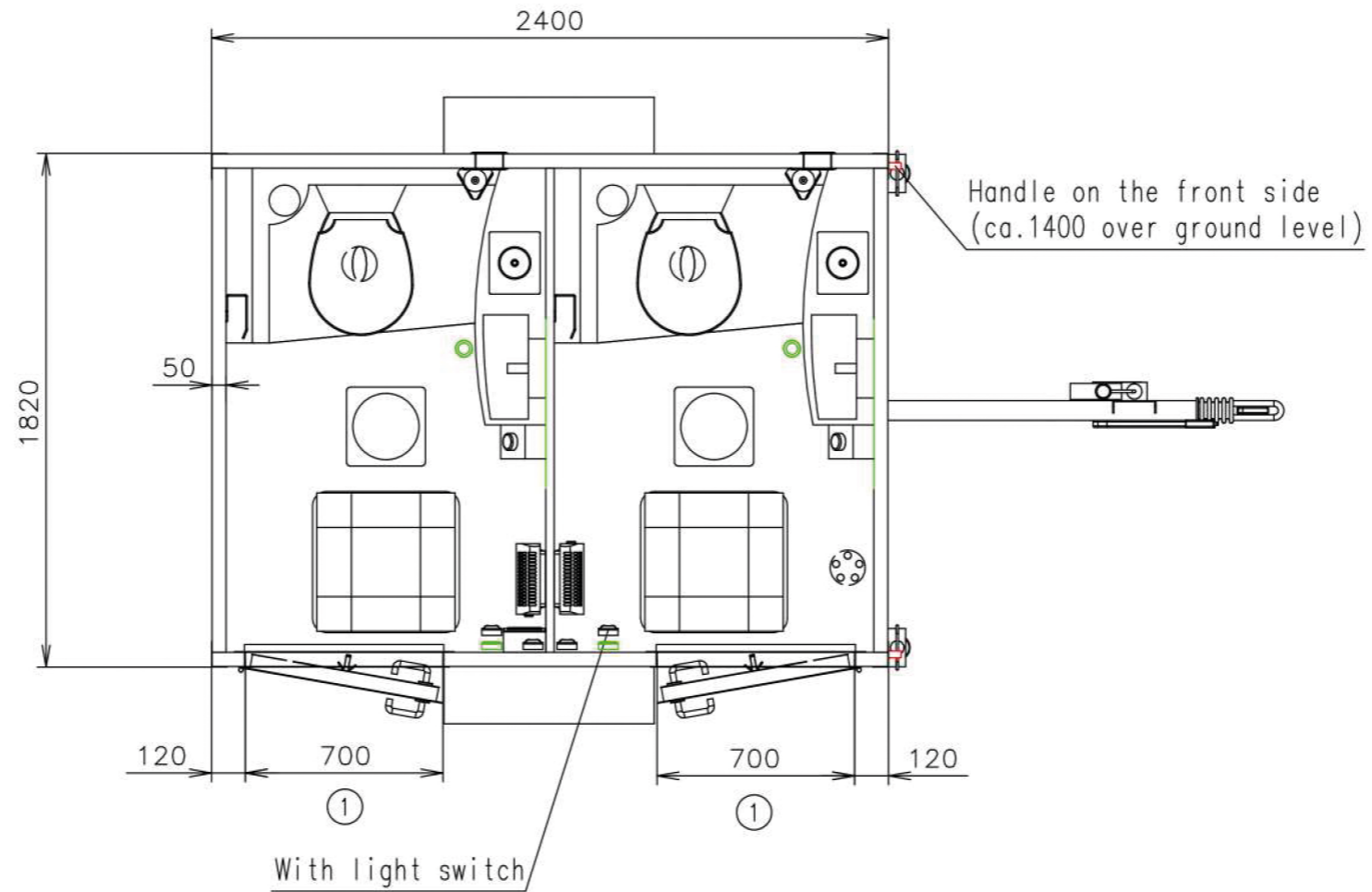

Notes:

Interior height:	2100 mm	Total weight:	750 kg
Color:	RAL 9010	Tare weight:	660 kg
Floor:	PVC black	Centre of wheels from rear side:	1200 mm
Date:	18.4.2018	Wheels:	165/70 R13

(Cabling and piping is not shown on the 3D views and drawings)

 **Sani Mobil**

Drawing number:
2xVIPWCTANKB-24-3_1/2

Connection hoses and cables

Water hose:	✗
Waste water hose:	✗
Electric cable:	✓

 Electric connection (on the chassis) (230V-16A)

 Effluent connection 2"

 Power point

 Light switch

 Switch board (under roof)

 Droplight

 Heating (500W)

 Floor drain hole

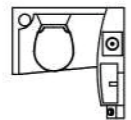

Tank system (toilet+wash-basin)(fresh water flush)
(110 l fresh, 160 l waste)



Roof window Dometic (400x400)

 Ventilation ø120

 Brush toilet

 Toilet paper holder

 Clothes hanger

 Mirror (600x600)

 Stairs Type 17

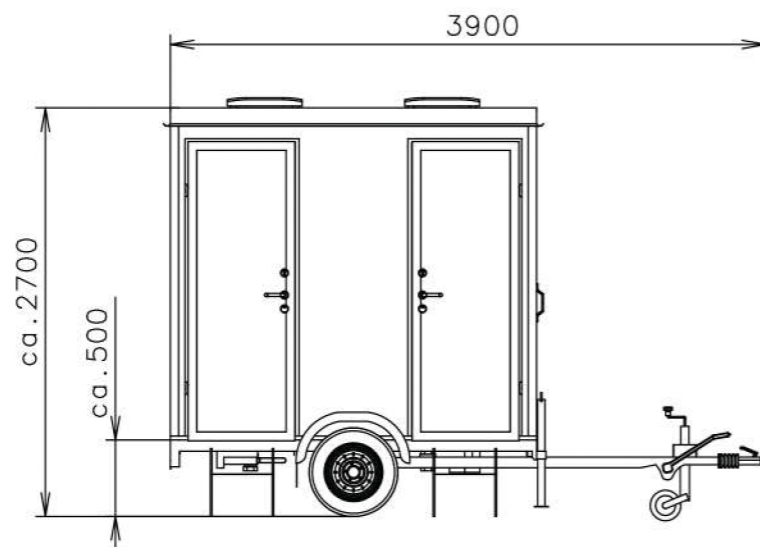

(Cabling and piping is not shown on the 3D views and drawings)

Notes:

Interior height:	2100 mm	Total weight:	750 kg
Color:	RAL 9010	Tare weight:	660 kg
Floor:	PVC black	Centre of wheels from rear side:	1200 mm
Date:	18.4.2018	Wheels:	165/70 R13

 **Sani Mobil**

Drawing number:

2xVIPWCTANKB-24-3_2/2