

Connection hoses and cables	
Water hose:	✓
Waste water hose:	✗
Electric cable:	✓

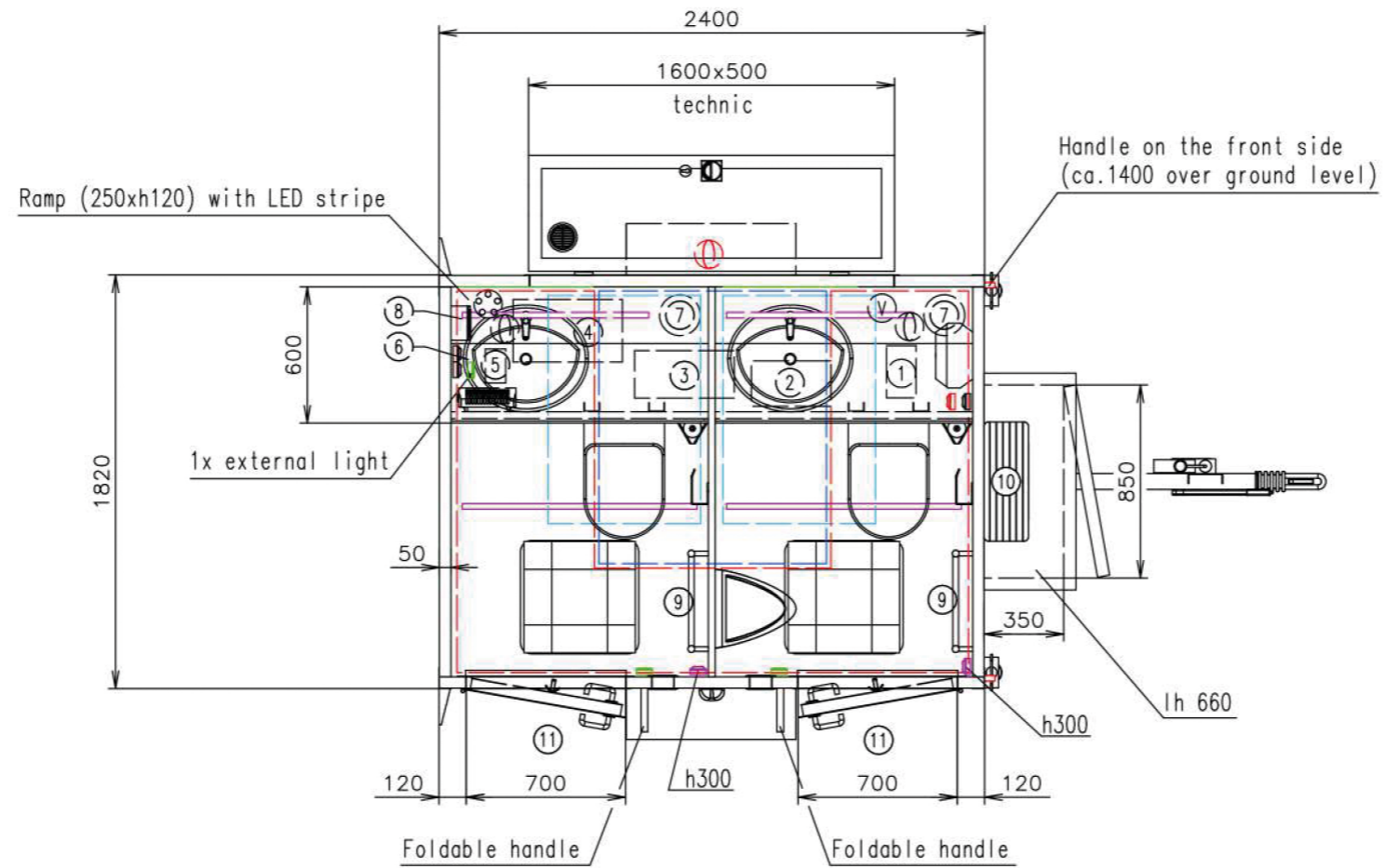

Water-level on the drawbar

2x extra toilet paper holder - under roof

Working desks in waterproof compact desk Egger (dark color)

Folio on doors - lady/man

Reinforcing of mudguards External LED lights

Water taps from DK Heatings + boiler only with external electric connection

Waste water from vacuum pump either to tank or directly out through wall under technic door

Notes:

Interior height:	2100 mm	Total weight:	1500 kg
Color:	RAL 9010 + folio	Tare weight:	1070 kg
Floor:	PVC black	Centre of wheels from rear side:	1200 mm
Date:	20.3.2017	Wheels:	195/50 R13C

 **Sani Mobil**

Drawing number:
2364-24-5_1/2 (MSB)

(Cabling and piping is not shown on the 3D views and drawings)

Connection hoses and cables	
Water hose:	✓
Waste water hose:	✗
Electric cable:	✓

- Ⓧ Water connection 3/4" (through the wall) + filter (connection point Geka 3/4")
- Ⓢ Electric connection (through the wall) (230V-16A)
- Ⓛ Effluent connection 2" (under floor from tank) or 1" (directly from Jets pump, through wall)
- Ⓧ Power point
- Ⓧ Power point 12V
- Ⓧ Thermostat of heating panel
- Ⓧ Light switch
- Ⓧ Switch board (500 over floor)
- Ⓧ LED stripe
- Ⓧ External sensor light - through light switch in technic room
- Ⓧ Heating (500W)
- Ⓧ Solar panel
- Ⓧ Wash-basin (built-in) Multi 1690 (550x470) + special water tap DK (mixed water)

- Ⓧ Vacuum toilet Jets
- Ⓧ Urinal - Uridan (waterless)
- Ⓧ Hot water boiler Wterm FHN (5l) + mixing water
- Ⓧ Waste-water tank (on the floor) (12250 x w1680 x h210 = 400l) + float senser + indicator
- Ⓧ Water tank (on the floor) (11000 x w1200 x h210 = 200l) + float senser + indicator
- Ⓧ Roof window Dometic (400x400)
- Ⓧ Ventilation ø120
- Ⓧ Brush toilet
- Ⓧ Toilet paper holder
- Ⓧ Clothes hanger
- Ⓧ Mirror (600x600)

- ① Water pump Shurflo (12V)
- ② Gray water tank Jets 12l
- ③ Vacuumator Jets ULTIMA C200 DC
- ④ Battery Banner Energy Bull 230Ah (12V)
- ⑤ Charger Multi XS 25A
- ⑥ Regulator EP Solar 20A
- ⑦ Speaker - in the ramp
- ⑧ Radio
- ⑨ Heating panel - white (w450 x h960) (300W) - through thermostat
- ⑩ Spare wheel on front wall
- ⑪ Standard free standing stairs (wooden steps)

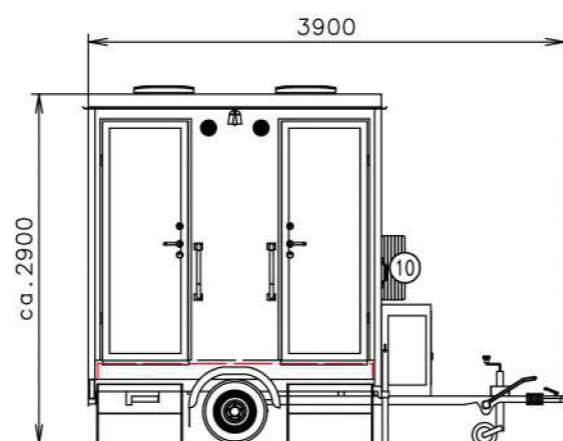

(Cabling and piping is not shown on the 3D views and drawings)

Water-level on the drawbar

2x extra toilet paper holder - under roof

Working desks in waterproof compact desk Egger (dark color)

Folio on doors - lady/man

Reinforcing of mudguards External LED lights

Water taps from DK Heatings + boiler only with external electric connection

Waste water from vacuum pump either to tank or directly out through wall under technic door

Notes:

Interior height:	2100 mm	Total weight:	1500 kg
Color:	RAL 9010 + folio	Tare weight:	1070 kg
Floor:	PVC black	Centre of wheels from rear side:	1200 mm
Date:	20.3.2017	Wheels:	195/50 R13C

Sani Mobil

Drawing number:
2364-24-5_2/2 (MSB)