

Connection hoses and cables	
Water hose:	✓
Waste water hose:	✗
Electric cable:	✓ 2x

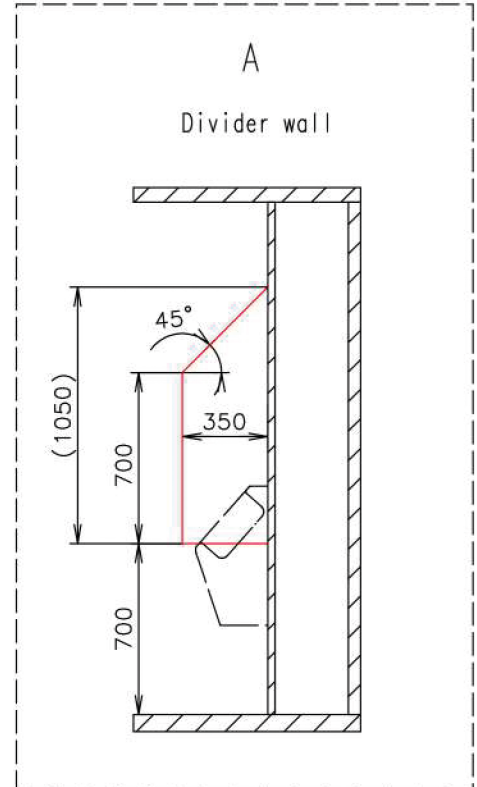

External light LED 071/730 (with inside lights)

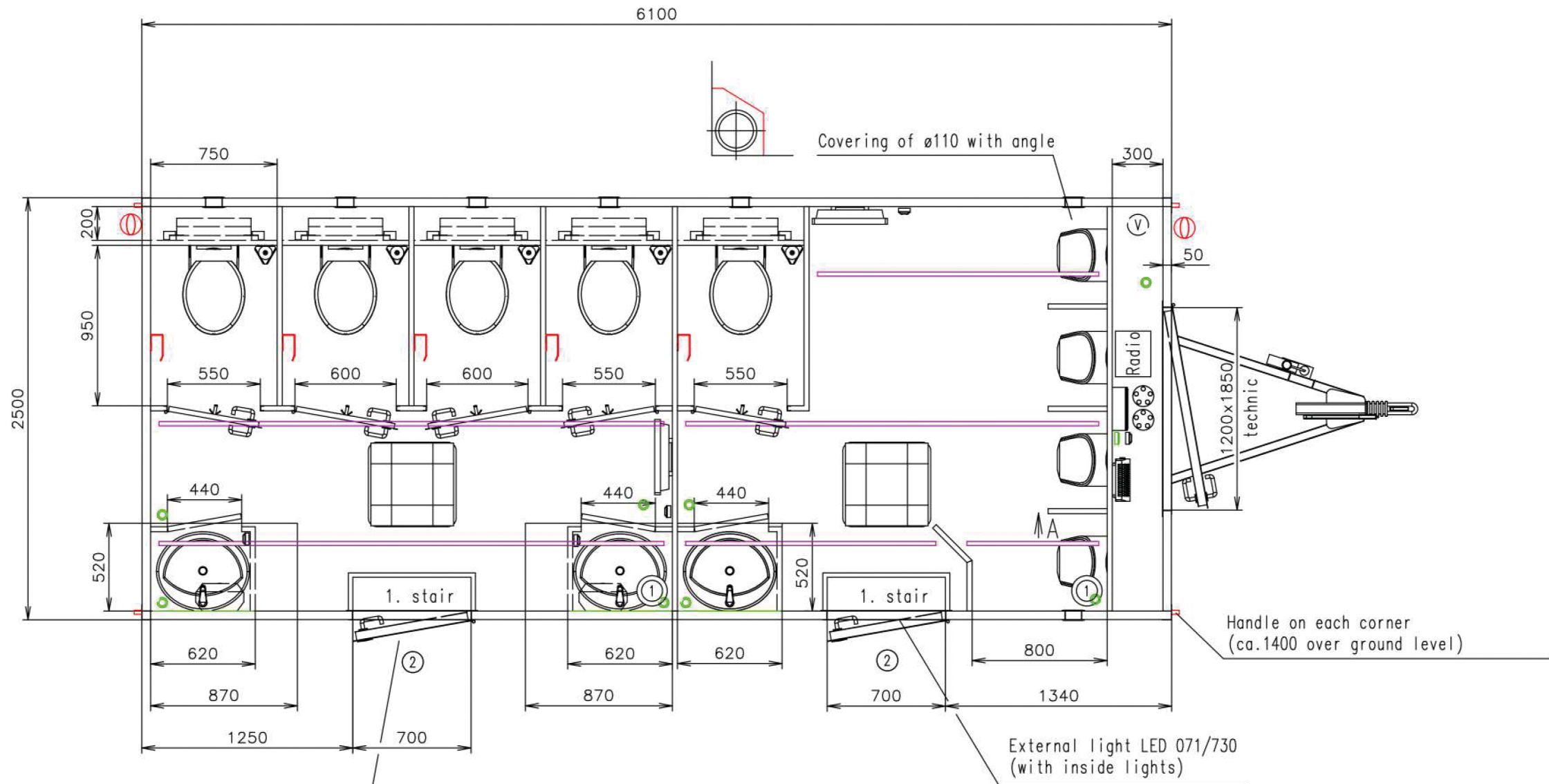
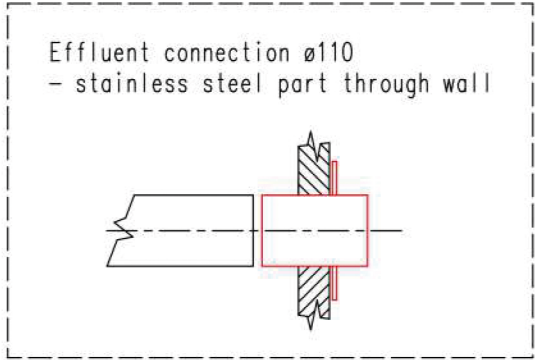
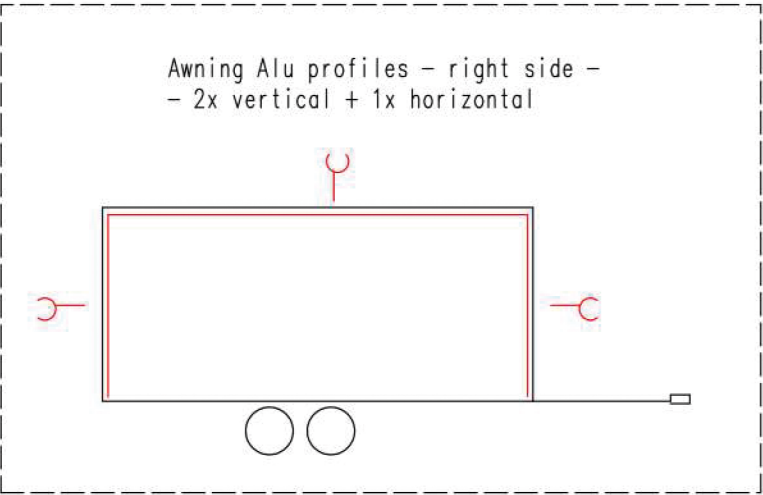

Working desks in waterproof compact desk Egger (dark color)

Interior doors + divider walls in black decor 6515

Notes: External doors - without cylinders Spare wheel - free loaded

Interior height:	2100 mm	Total weight:	2000 kg
Color:	RAL 7042 (gray)	Tare weight:	1990 kg
Floor:	PVC Jupiter 148708	Centre of wheels from rear side:	2990 mm
Date:	18.12.2017	Wheels:	155 R13

(Cabling and piping is not shown on the 3D views and drawings)



Drawing number:
2557-61-2_1/2 (Sprenger)

Connection hoses and cables	
Water hose:	✓
Waste water hose:	✗
Electric cable:	✓ 2x

Ⓥ Water connection 3/4" (on the chassis)
+ filter + reduction valve

Ⓜ 2x Electric connection (through the floor)
(230V-16A) (1x heatings) (1x the rest)

Ⓞ 2x Effluent connection ø110 (through wall)
- stainless steel part

Ⓟ Power point

Ⓛ Light switch

Ⓛ Switch board (1200 over floor)

— Light LED stripe

Ⓜ Heating (500W)

Ⓜ Heating (750W)

Ⓞ Floor drain hole

Ⓛ Ventilation ø120

Ⓞ Wash-basin (built-in) Multi 1690 (550x470)
+ standard water tap

Ⓞ Hanging toilet (toilet seat - steel holders)

Ⓞ Urinal - Vitra Siko (water flush)

Ⓞ Hot water boiler Wterm FHN (5l)

Ⓞ Roof window Dometic (400x400)

Ⓞ Brush toilet

Ⓞ Special toilet paper holder

Ⓞ Clothes hanger

— Mirror (600x600) + black frame around

① Speaker

② Foldable stairs Fiona
(update on fixing of stair)
+ stainless steel handrail

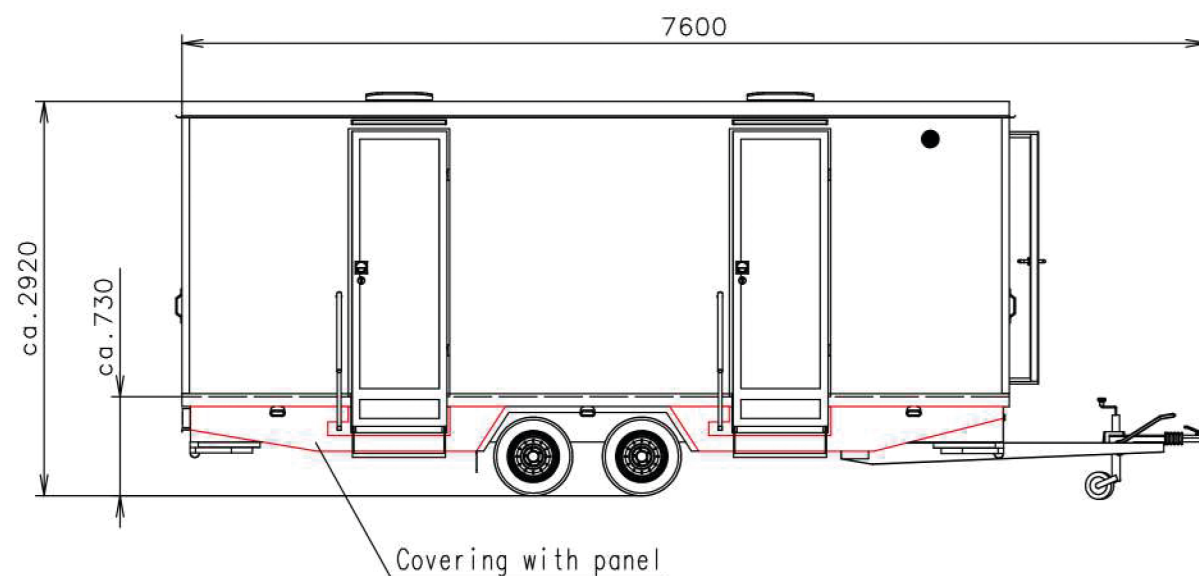

(Cabling and piping is not shown on the 3D views and drawings)

Working desks in waterproof compact desk Egger (dark color)

Interior doors + divider walls in black decor 6515

Notes: External doors - without cylinders Spare wheel - free loaded

Interior height:	2100 mm	Total weight:	2000 kg
Color:	RAL 7042 (gray)	Tare weight:	1990 kg
Floor:	PVC Jupiter 148708	Centre of wheels from rear side:	2990 mm
Date:	18.12.2017	Wheels:	155 R13

 **Sani Mobil**

Drawing number:
2557-61-2_2/2 (Sprenger)