

Connection hoses and cables	
Water hose:	✓
Waste water hose:	✗
Electric cable:	✓

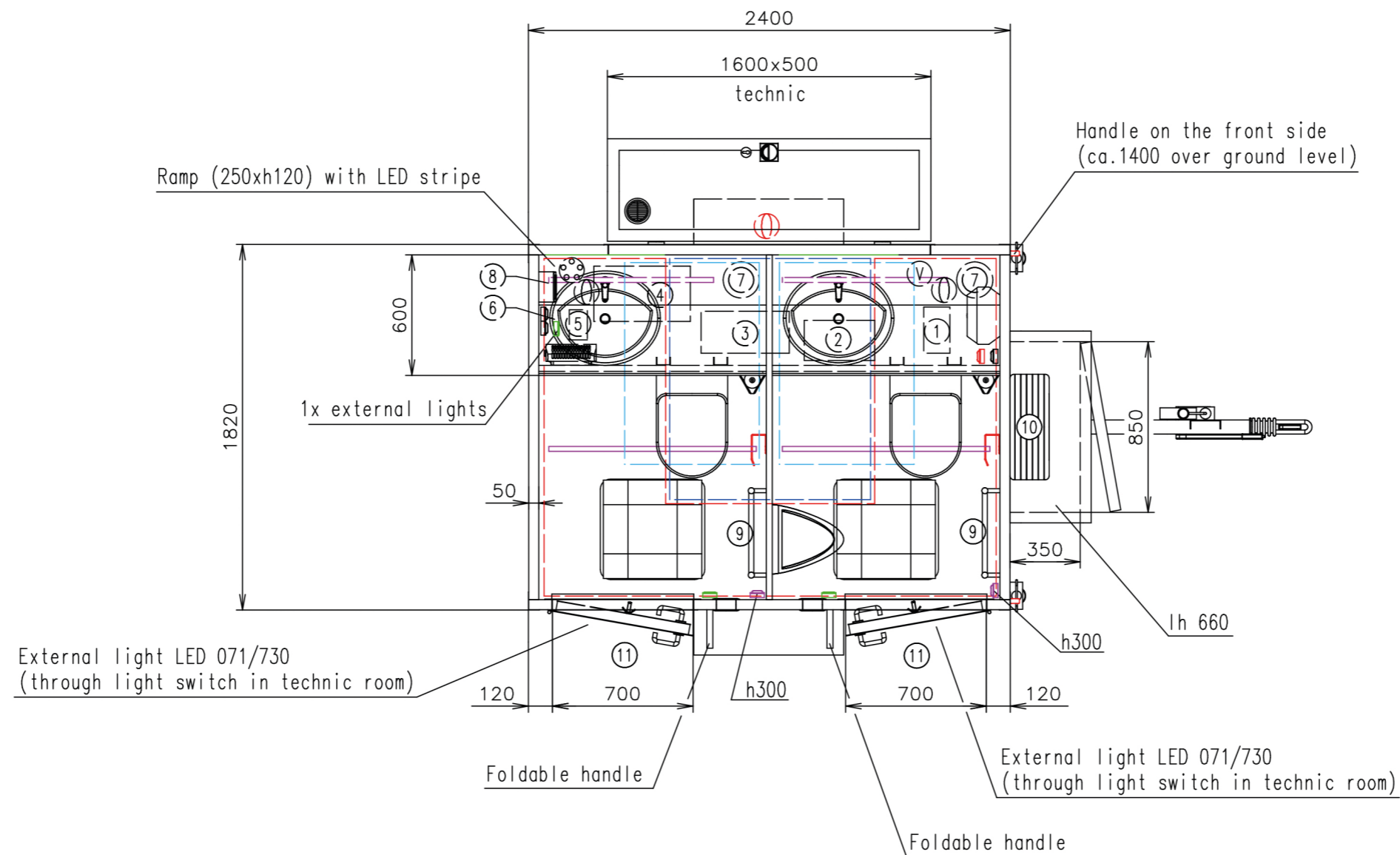

External doors – without cylinders

Working desks in waterproof compact desk Egger (dark color)

Heatings + boiler only with external electric connection

Notes: Waste water from vacuum pump either to tank or directly out through wall under technic door

Interior height:	2100 mm	Total weight:	1500 kg
Color:	RAL 7042	Tare weight-estimate:	1100 kg
Floor:	PVC Jupiter 148708	Centre of wheels from rear side:	1200 mm
Date:	19.12.2017	Wheels:	195/50 R13C

 **Sani Mobil**

Drawing number:
2855-24-1_1/2 (Sprenger)

(Cabling and piping is not shown on the 3D views and drawings)

Connection hoses and cables	
Water hose:	✓
Waste water hose:	✗
Electric cable:	✓

- Ⓥ Water connection 3/4" (through the wall) + filter + reduction valve
- Ⓢ Electric connection (through the wall) (230V-16A)
- Ⓛ Effluent connection 2" (under floor from tank) or 1" (directly from Jets pump, through wall)
- Ⓜ Power point
- Ⓜ Power point 12V
- Ⓜ Thermostat of heating panel
- Ⓜ Light switch
- Ⓜ Switch board (500 over floor)
- LED stripe
- Ⓜ Heating (500W)
- Solar panel
- Ⓢ Wash-basin (built-in) Multi 1690 (550x470) + standard water tap

- Ⓛ Vacuum toilet Jets
- Ⓢ Urinal - Uridan (waterless)
- Ⓜ Hot water boiler Wterm FHN (5l)
- Ⓜ Waste-water tank (on the floor) (12250 x w1680 x h210 = 400l) + float sensor + indicator
- Ⓜ Water tank (on the floor) (11000 x w1200 x h210 = 200l) + float sensor + indicator
- Ⓜ Roof window Dometic (400x400)
- Ⓜ Ventilation ø120
- Ⓢ Brush toilet
- Ⓜ Special toilet paper holder
- Ⓢ Clothes hanger
- Mirror (600x600) + black frame around

- ① Water pump Shurflo (12V)
- ② Gray water tank Jets 12l
- ③ Vacuumator Jets ULTIMA C200 DC
- ④ Battery Banner Energy Bull 230Ah (12V)
- ⑤ Charger Multi XS 25A
- ⑥ Regulator EP Solar 20A
- ⑦ Speaker - in the ramp
- ⑧ Radio
- ⑨ Heating panel - white (w450 x h960) (300W) - through thermostat
- ⑩ Spare wheel on front wall
- ⑪ VIP stairs

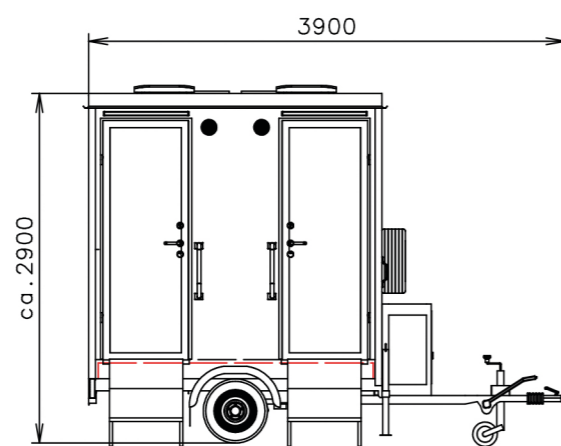

(Cabling and piping is not shown on the 3D views and drawings)

External doors - without cylinders

Working desks in waterproof compact desk Egger (dark color)

Heatings + boiler only with external electric connection

Waste water from vacuum pump either to tank or directly out through wall under technic door

Notes:

Interior height:	2100 mm	Total weight:	1500 kg
Color:	RAL 7042	Tare weight-estimate:	1100 kg
Floor:	PVC Jupiter 148708	Centre of wheels from rear side:	1200 mm
Date:	19.12.2017	Wheels:	195/50 R13C

 **Sani Mobil**

Drawing number:
2855-24-1_2/2 (Sprenger)